



ANAF Fire Protection
an ANAFGROUP company

ANAF España
an ANAFGROUP company

ANAF France
an ANAFGROUP company

ANAF Luxembourg
an ANAFGROUP company



Group Presentation

Anafgroup

About us



We are the European leader in the design, production, and distribution of portable and wheeled fire extinguishers for firefighting, automotive and marine; we have significant references by the international producers



We have a complete range of firefighting products, accessories and spare parts: portable, automatic and wheeled fire extinguishers; fire systems; firefighting products; fire alarm and detection



With a production of 4.5 million pieces of fire extinguishers, we are the most significant European manufacturer



Corporate Structure

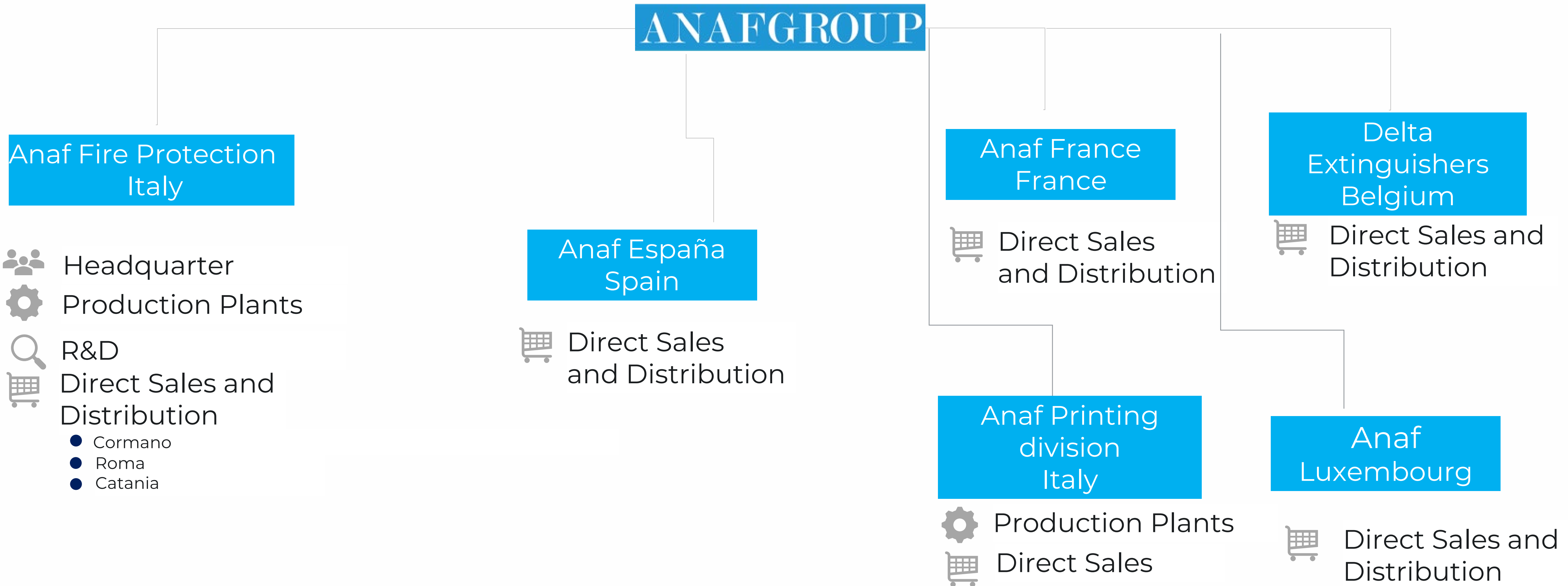

Italian by the heart...



Our headquarter is based in Torre d'Isola

- 3 Local Units throughout Italy:
 - Cormano
 - Roma
 - Catania

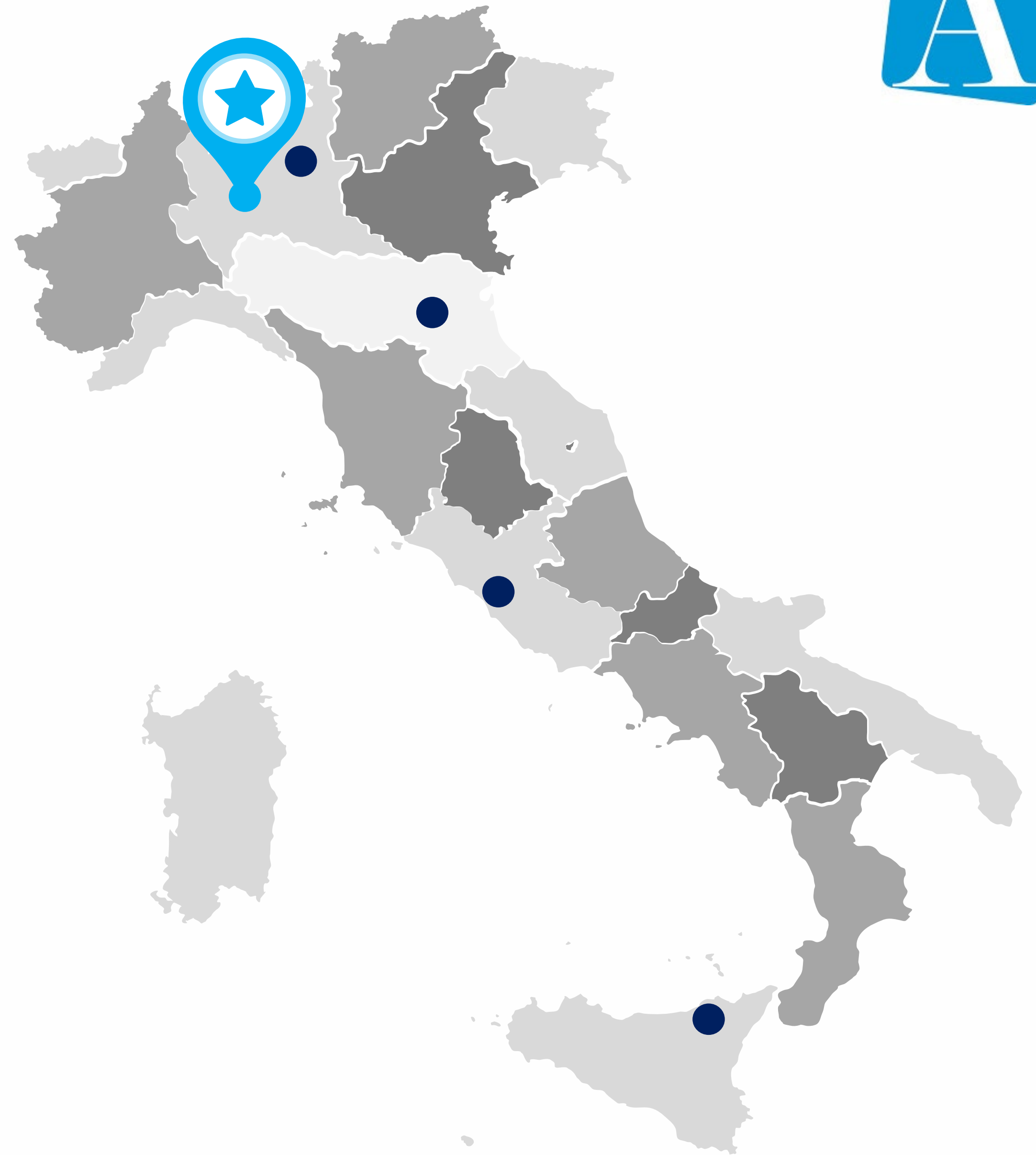

...with a European vocation...



Italian Headquarter



Anaf France (Longwy, Lyon)



Anaf Luxembourg (Differdange)



Anaf Spain (Barcelona)



Delta (Ethe)

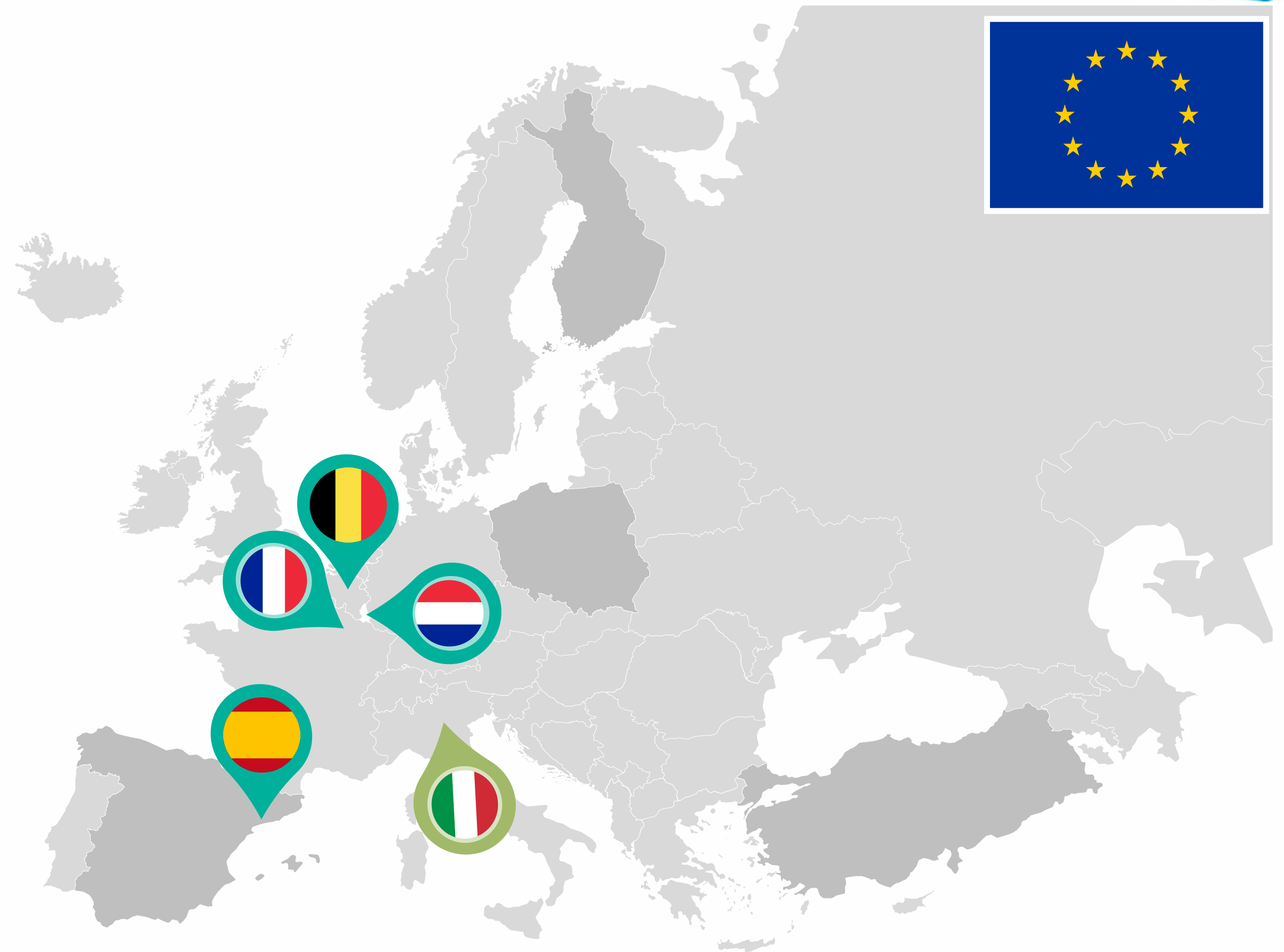

...and a global perspective!



We serve more than 1.800 customers in 70 countries

Albania Saudi Arabia Austria Azerbaijan Belgium Belarus Bosnia Herzegovina Bulgaria Canada Chile China Cyprus Ivory Coast Croatia Curacao Danmark Egypt UAE Estonia Ethiopia Finland France Georgia Germany Greece Honk Kong India Indonesia Iran Iraq Ireland Iceland Salomon Iceland South Korea Kuwait Latvia Luxembourg Macao Macedonia Madagascar Malta Morocco Montenegro Niger Norway Netherlands Oman Pakistan Panama Poland Portugal Qatar United Kingdom Czeck Republic Romania Russia Senegal Serbia Singapore Slovak Slovenia Spain USA South Africa Sweden Taiwan Turkey Ukraine Hungary Vietnam

Anafgroup in a nutshell



Established in 1973

A global group, founded and owned by Yves Anaf



Turnover of >46 mil €

More than 300 employees



4 corporate certifications

(EN 14001, EN 9001, BS 18001, EN 9100)



From local presence to global leadership

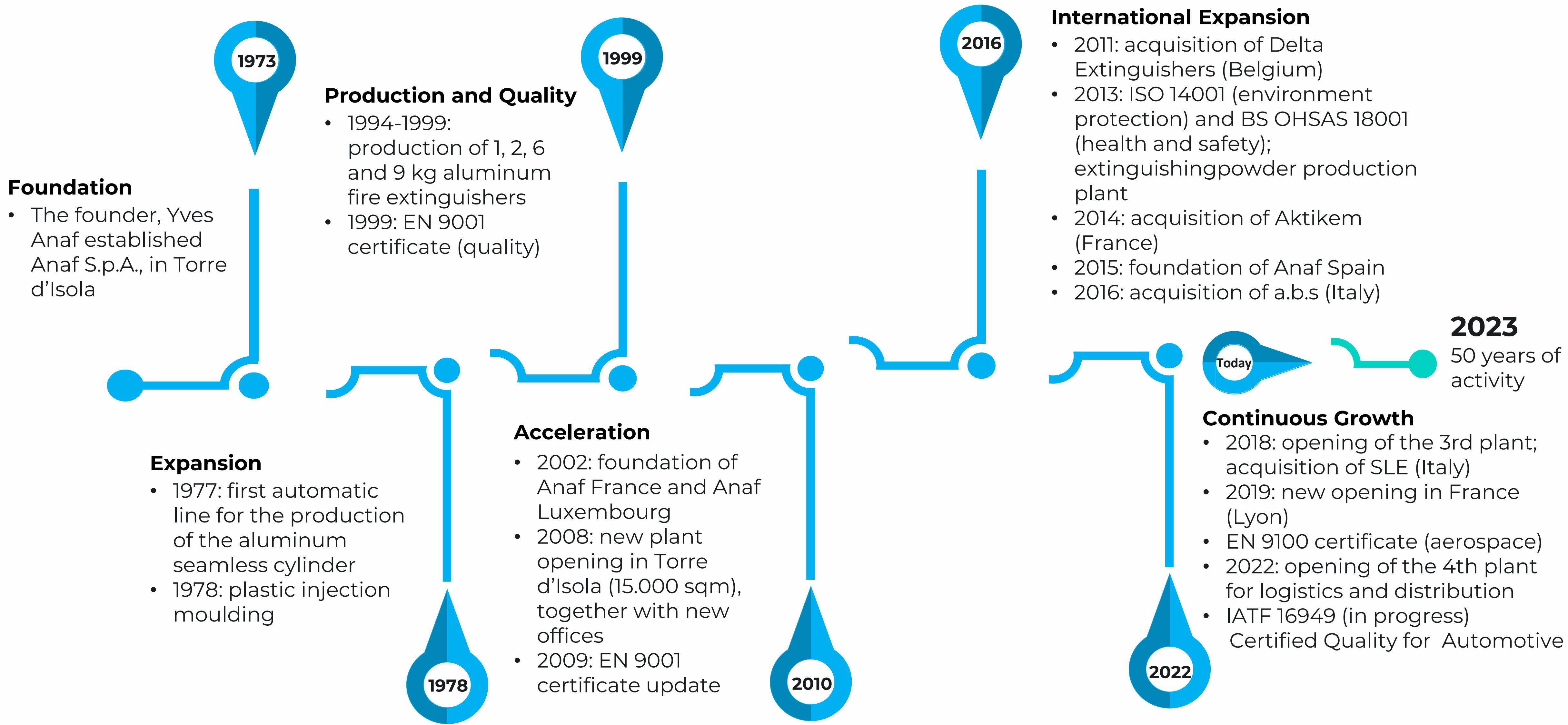

The pillars of our strategy

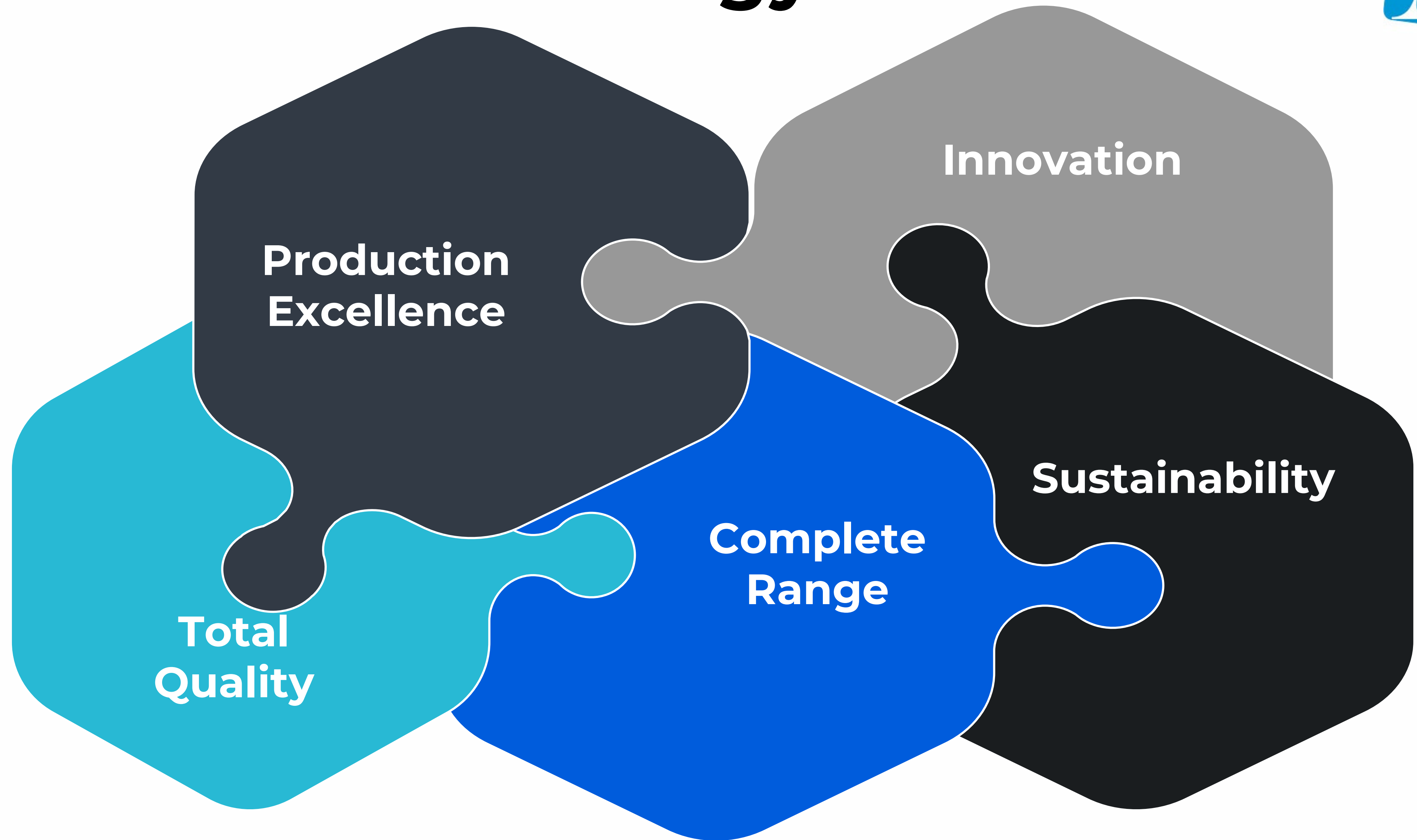

The pillars of our strategy

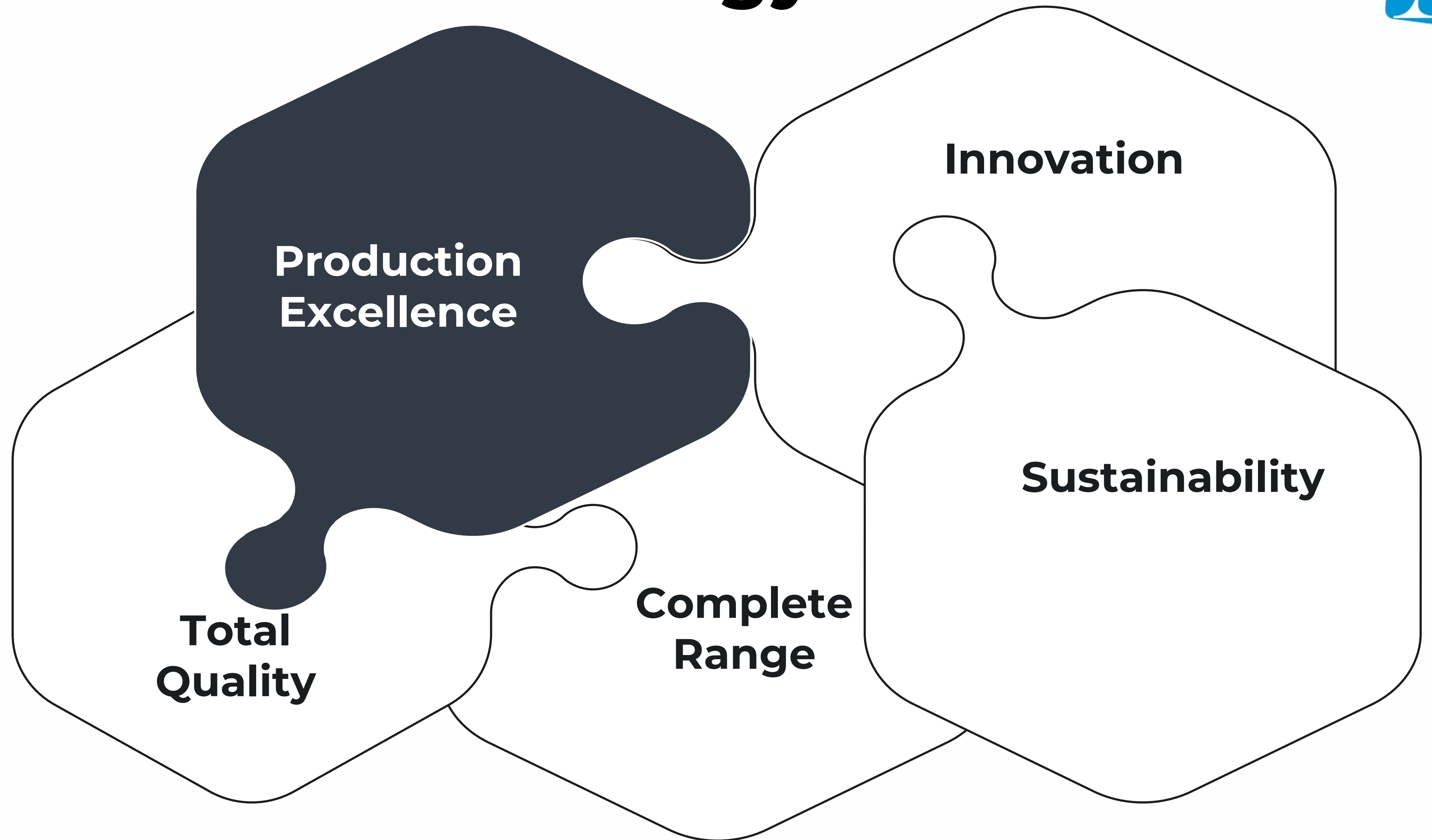

Full control of the manufacturing



Laser cutting



Powder production

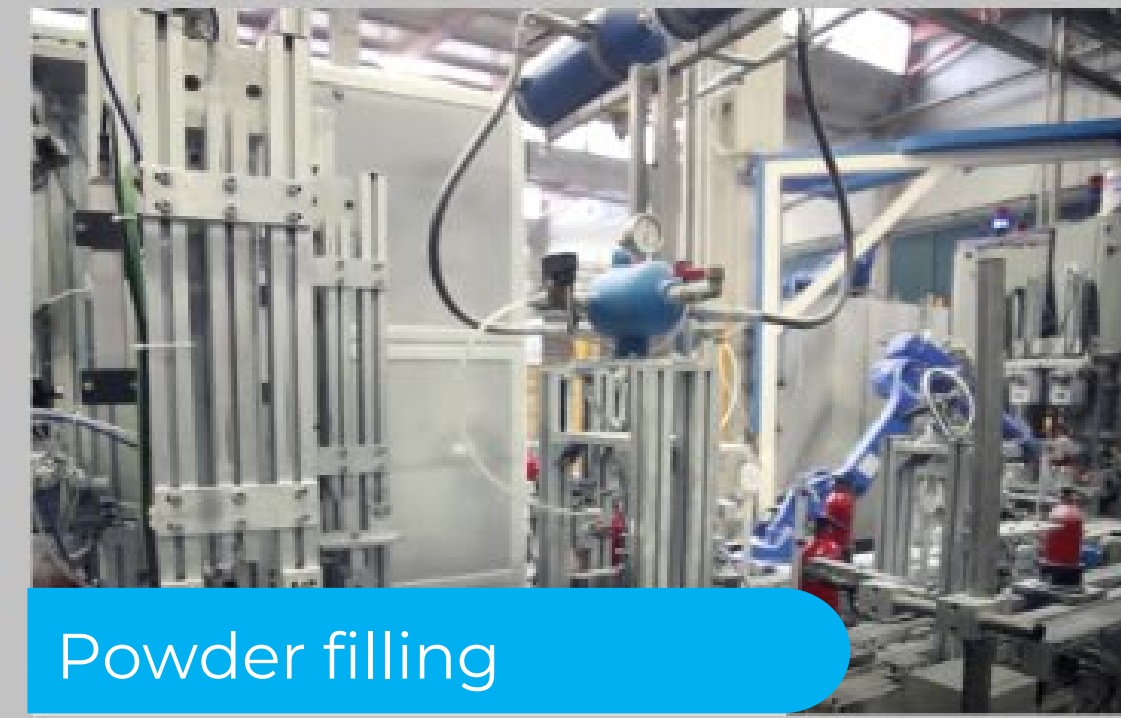

Powder filling



Plastic injection machines



Painting



Screen printing



Assembling



Packaging



Logistics

We manufacture more than 95% of the components in our factories, extinguishing powder included

We manufacture our extinguishing powder

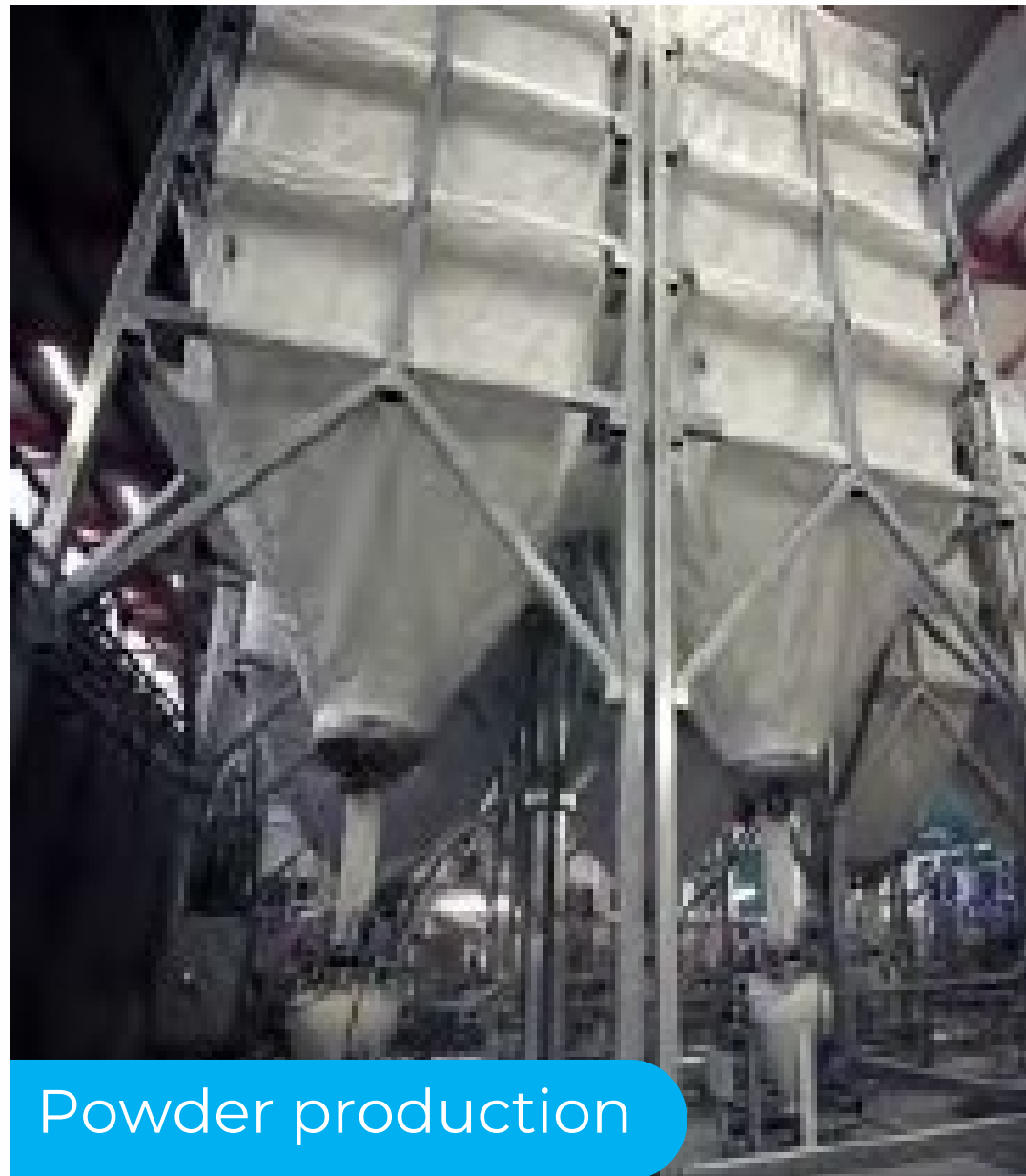

Powder production

- Our internal plant has a production capacity of 4.7 ton per hour
- Granulometry constantly laser controlled
- The powder filling line is directly connected to the plant: the extinguishing agent doesn't get in contact with humidity

We can produce any kind of powder and foam



Powder production

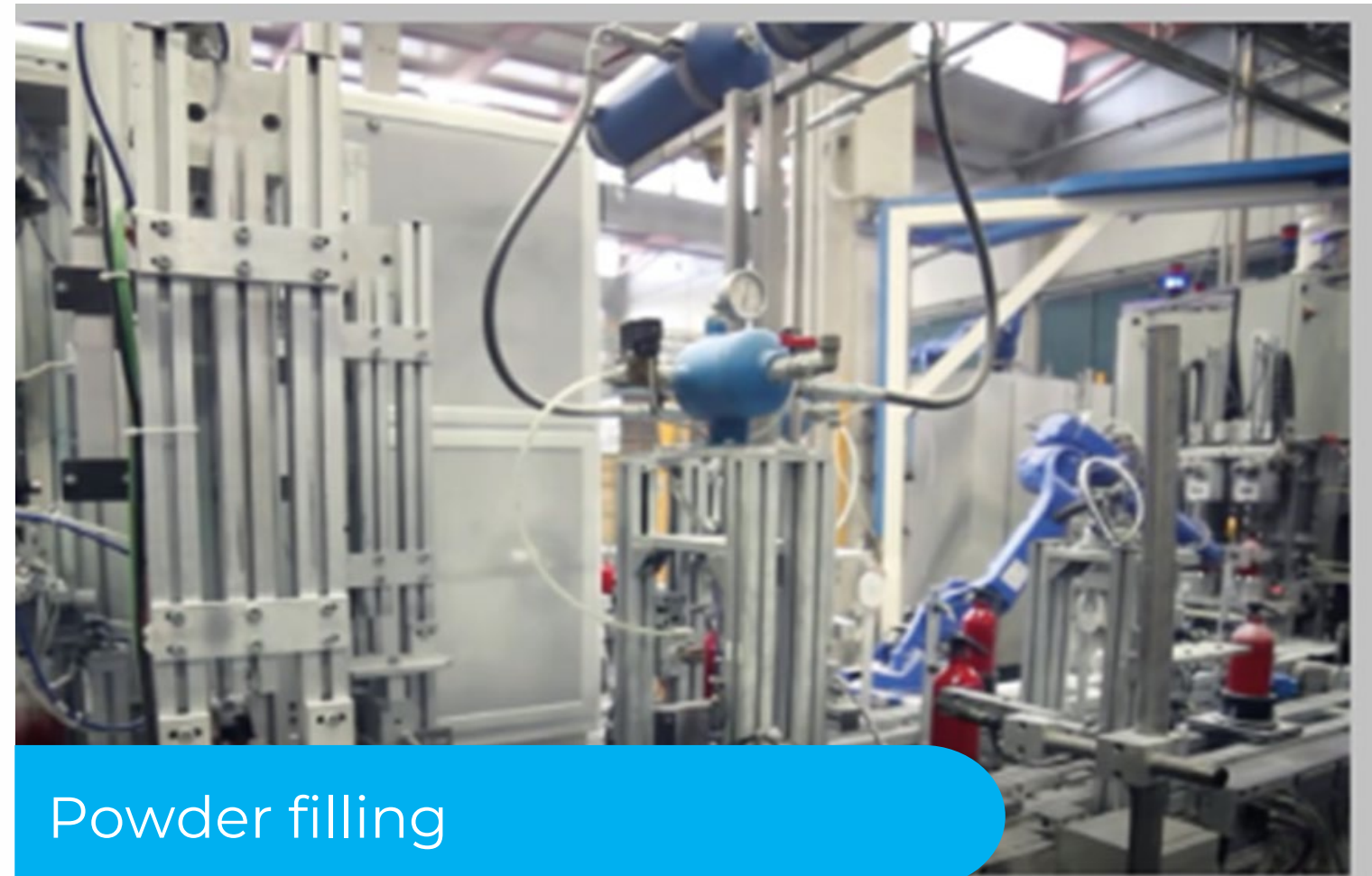

Powder filling



Powder production

The pillars of our strategy

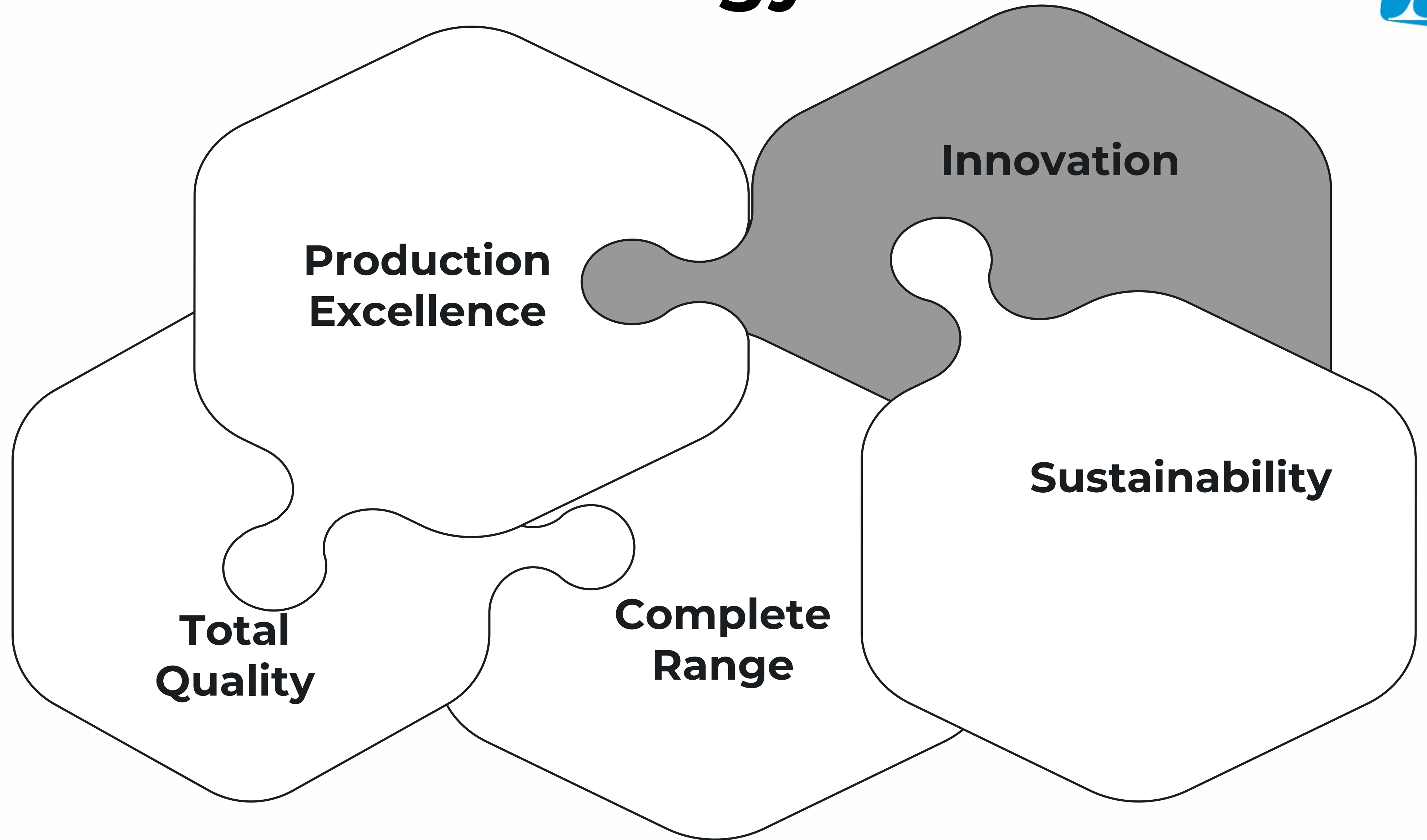

Internal innovation

Our products and services are created, developed and manufactured in our Anaf factories and with external reliable and audited partners. We always make sure our products match the same high-quality standards, stricter than the regulation



50 years in the designing of firefighting products



Since 1978, Yves Anaf sits at the technical committees for the fire extinguishers regulation in Italy (UNI) and in Europe (CEN)



Experience in several industries:

- Automotive
- Marine
- Aircraft

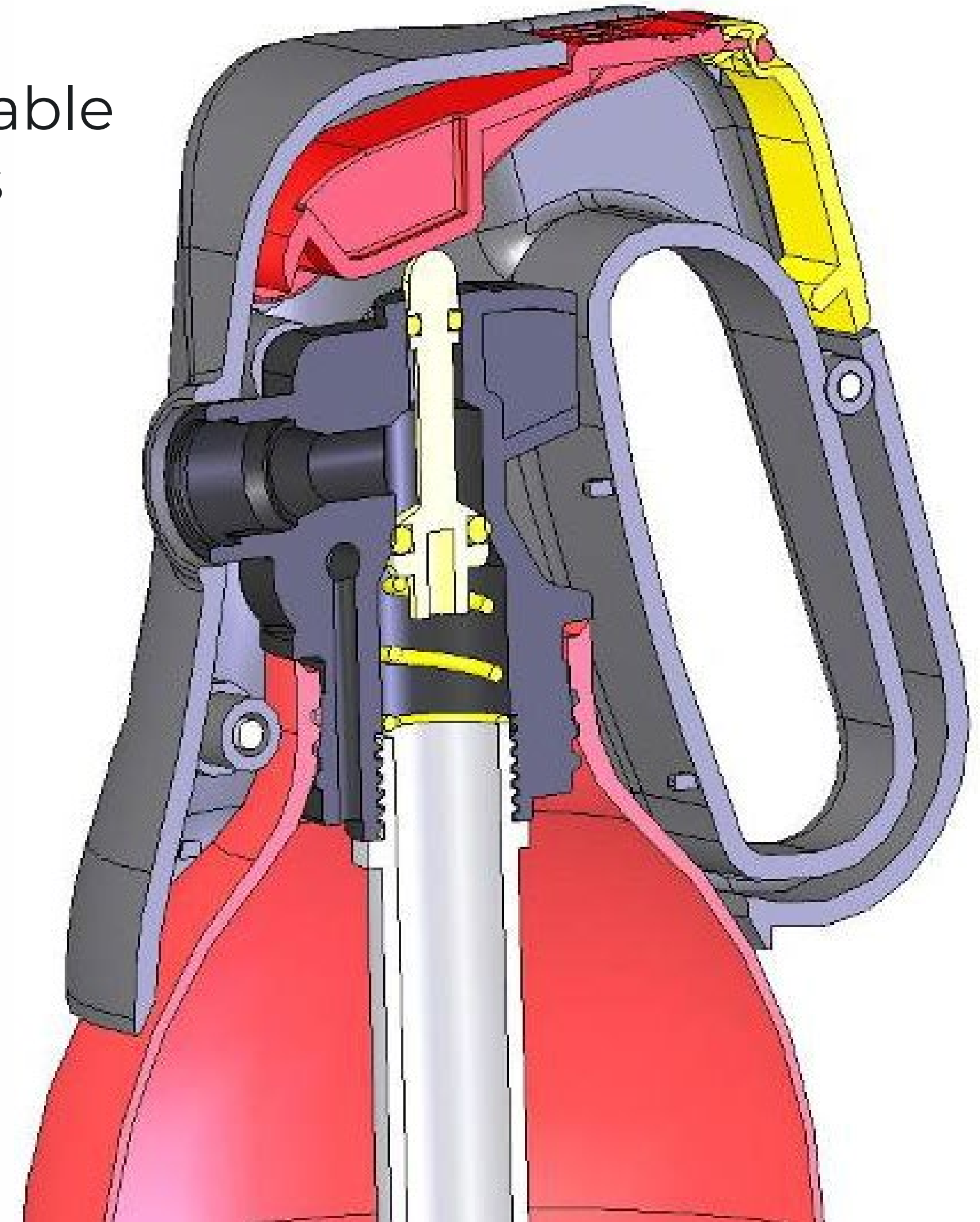

R&D and Testing

We have an internal laboratory for testing; our standards are comparable to the ones of the certifying labs.



We check each fire extinguisher at least 50 times, from its origin until it is ready for delivery

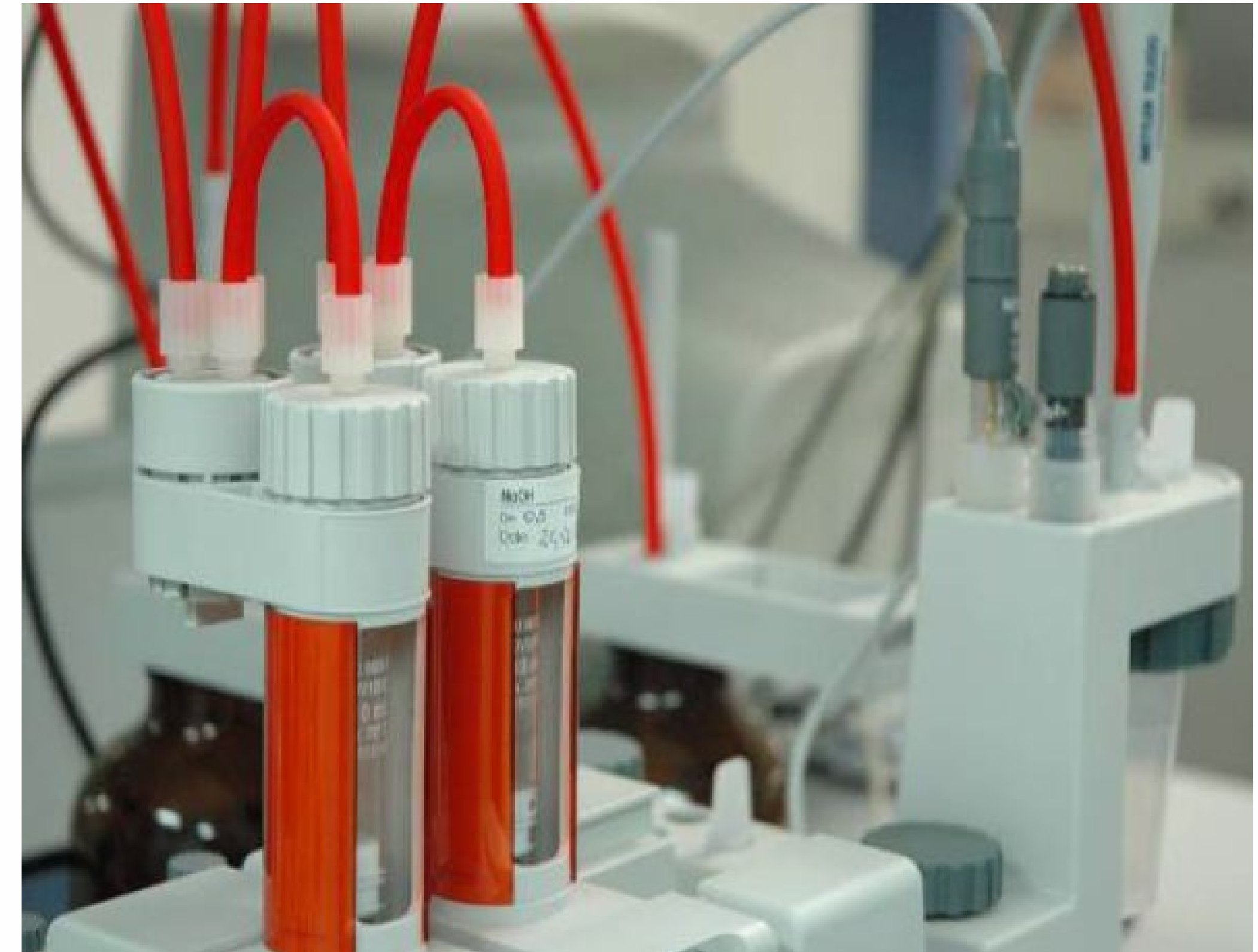

The pillars of our strategy

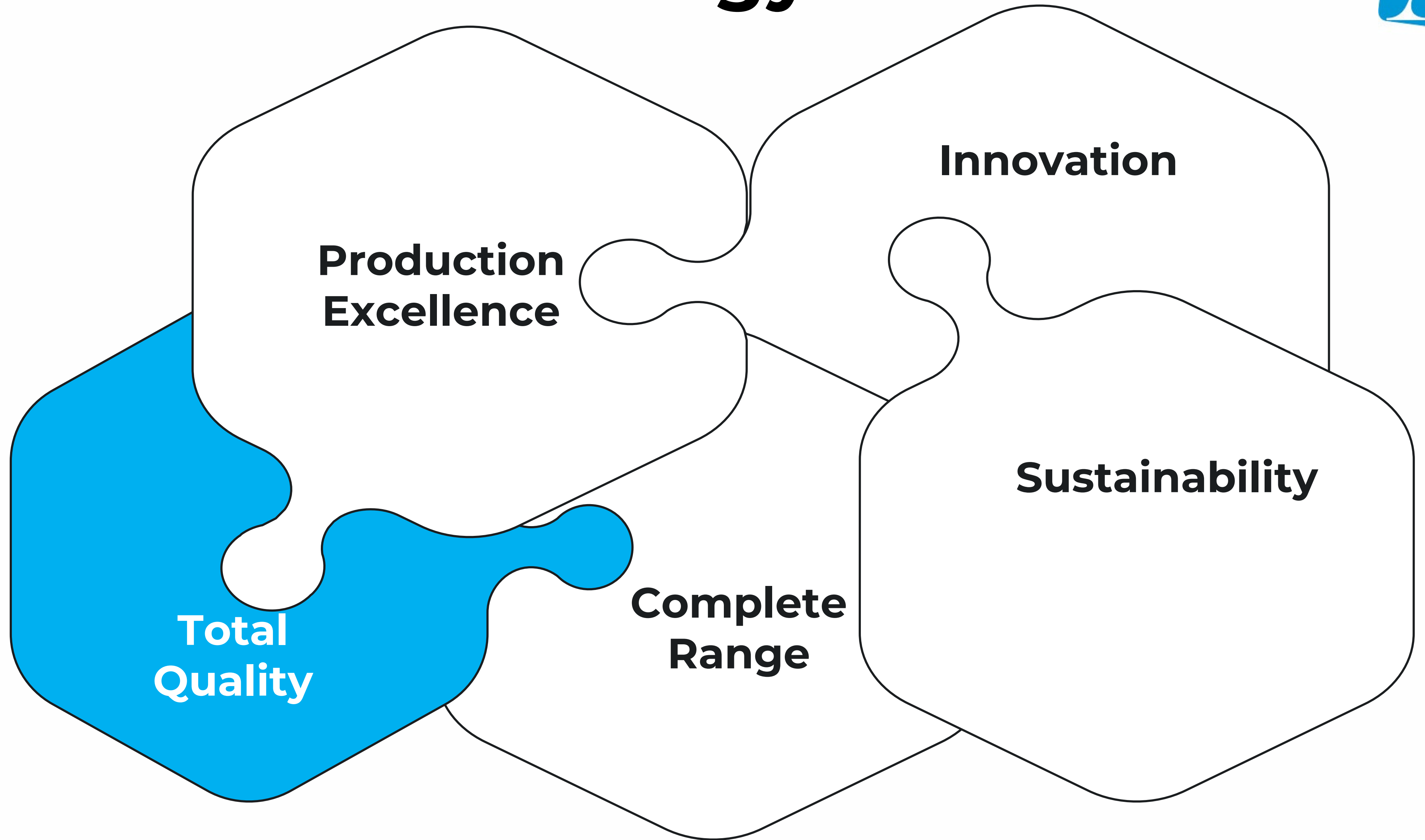

Certified Quality



For us, quality is much more than a word: it is deeply embedded in our DNA. Since we aim at Top Quality in everything we do, we established a rigorous Quality Management System, covering all aspects of the group



UNI EN ISO 9001: 2015
Certified Quality
Management



UNI EN ISO 14001: 2015
Certified
Environmental
Management



UNI EN ISO 9100: 2018
Certified Quality for
Aerospace and Defense



IATF 16949 (in progress)
Certified Quality for
Automotive



UNI EN ISO 45001: 2018
Certified Safety
Management

Certified Quality



Products are certified by the competent lab in each country.



We have more than 300 product certificates

The pillars of our strategy

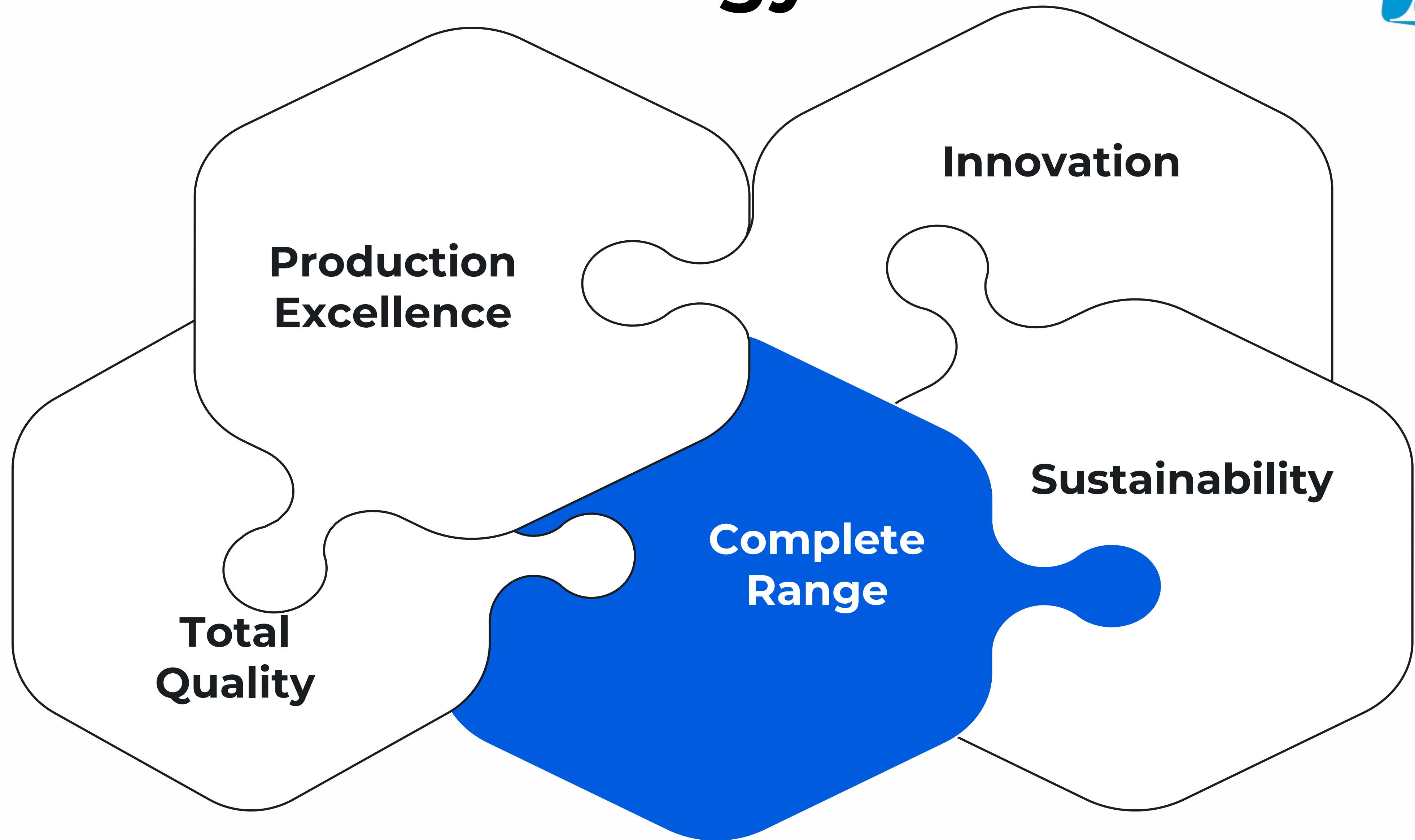

Complete and wide range for each industry

Aircraft



Marine

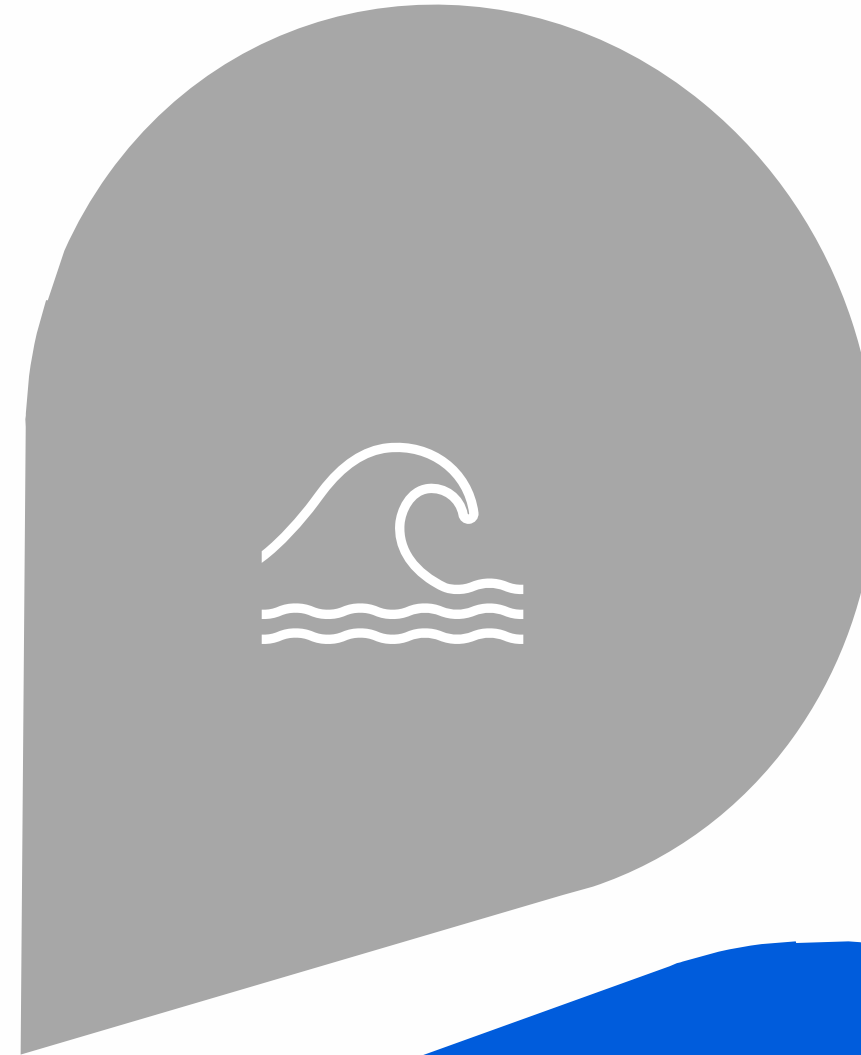

Automotive



Fire Fighting



Retail



The pillars of our strategy

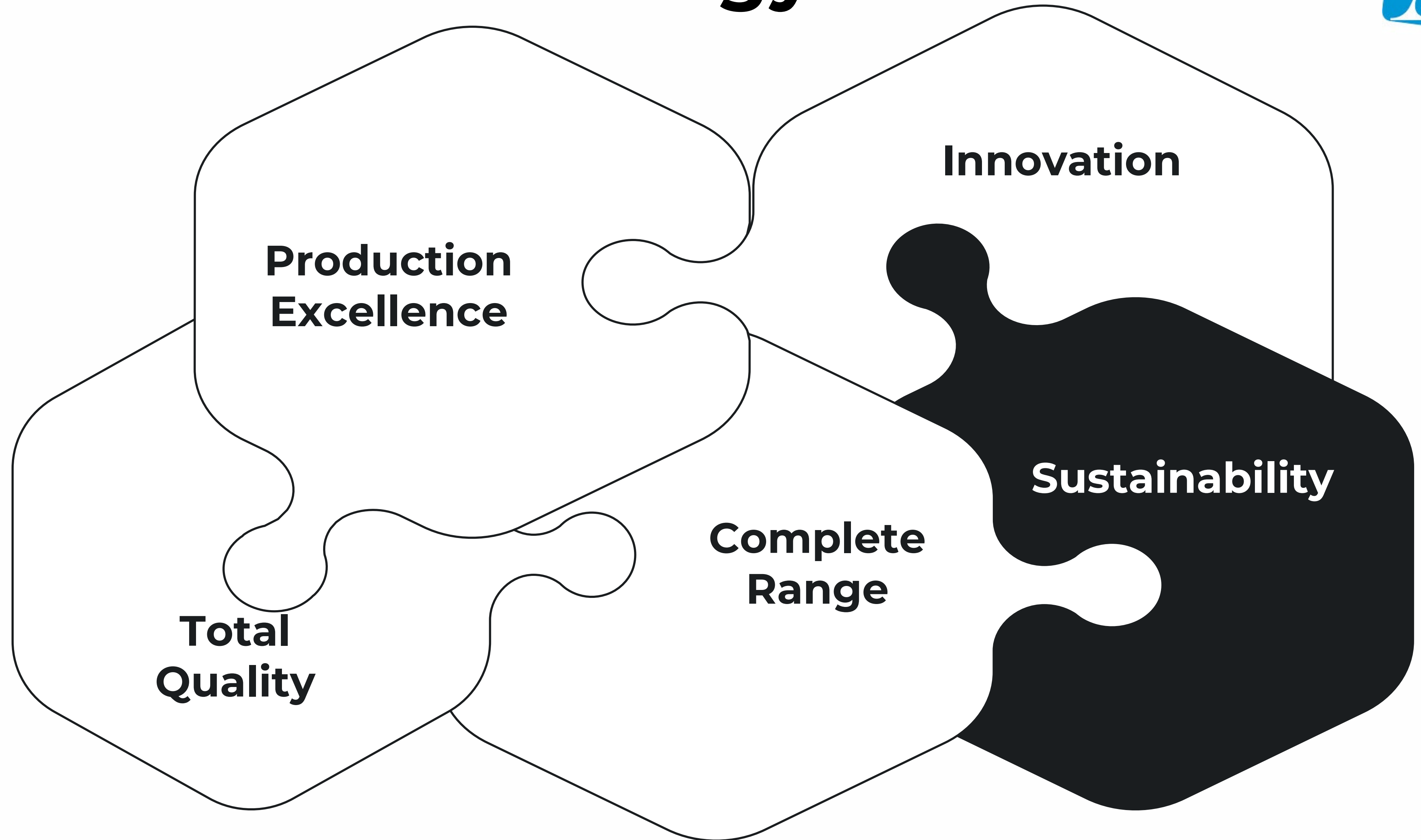

Sustainability



Corporate social responsibility is not an abstract concept for us, but consists in daily concrete practices, designed to balance economic decisions against an assessment of their social and environmental impact in relation to the expectations of all Group stakeholders



Our references



Contacts



Anaf Fire Protection S.p.A.

Via del Commercio, 4
27020 Torre d'Isola (Italy)



0039 0382 4533



info@anaf.eu
www.anaf.eu